



US006917160B2

(12) **United States Patent**  
**Koo et al.**

(10) **Patent No.:** **US 6,917,160 B2**  
(45) **Date of Patent:** **Jul. 12, 2005**

(54) **ORGANIC ELECTROLUMINESCENT DISPLAY AND METHOD OF MANUFACTURING THE SAME**

**FOREIGN PATENT DOCUMENTS**

(75) Inventors: **Jae-Bon Koo**, Yongin (KR); **Sang-II Park**, Seoul (KR)

JP	62-172691	7/1987
JP	63-172691	7/1988
JP	64-15982	1/1989
JP	1-220394	9/1989
JP	11-283751	10/1999
JP	2001-230086	8/2001

(73) Assignee: **Samsung SDI Co., Ltd.**, Suwon-si (KR)

(\*) Notice: Subject to any disclaimer, the term of this patent is extended or adjusted under 35 U.S.C. 154(b) by 128 days.

*Primary Examiner*—Vip Patel

(74) *Attorney, Agent, or Firm*—Stein, McEwen & Bui, LLP

(57) **ABSTRACT**

(21) Appl. No.: **10/663,800**

An organic electroluminescent display and a method of manufacturing the same are provided. The organic electroluminescent display includes a substrate, at least a thin-film transistor, which is formed on the substrate, at least an insulation layer, which cover the thin-film transistor, first electrodes, which are formed in a predetermined pattern on a top surface of the insulation layer and to which a voltage is selectively applied through the thin-film transistor, bus electrodes, which are insulated from the first electrodes, a planarization layer, which is an insulation layer and has openings exposing the first electrodes and the bus electrodes, organic layers, which are formed on a top surface of the first electrodes, and second electrodes, which are formed on a top surface of the organic layer and a top surface of the planarization layer and are electrically connected to the bus electrodes.

(22) Filed: **Sep. 17, 2003**

(65) **Prior Publication Data**

US 2004/0056591 A1 Mar. 25, 2004

(30) **Foreign Application Priority Data**

Sep. 19, 2002 (KR) ..... 10-2002-0057336

(51) **Int. Cl.**<sup>7</sup> ..... **H01J 1/62**

(52) **U.S. Cl.** ..... **313/506; 313/504**

(58) **Field of Search** ..... 313/498, 504, 313/506, 509, 512

(56) **References Cited**

**U.S. PATENT DOCUMENTS**

6,538,374 B2 3/2003 Hosokawa

**7 Claims, 4 Drawing Sheets**

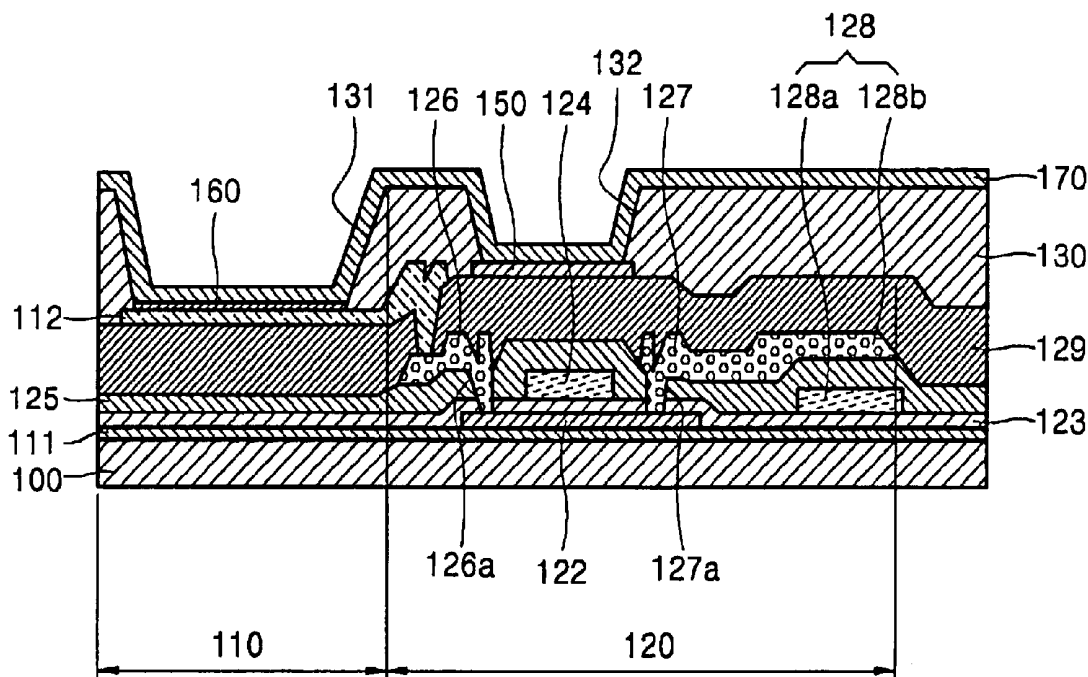

FIG. 1

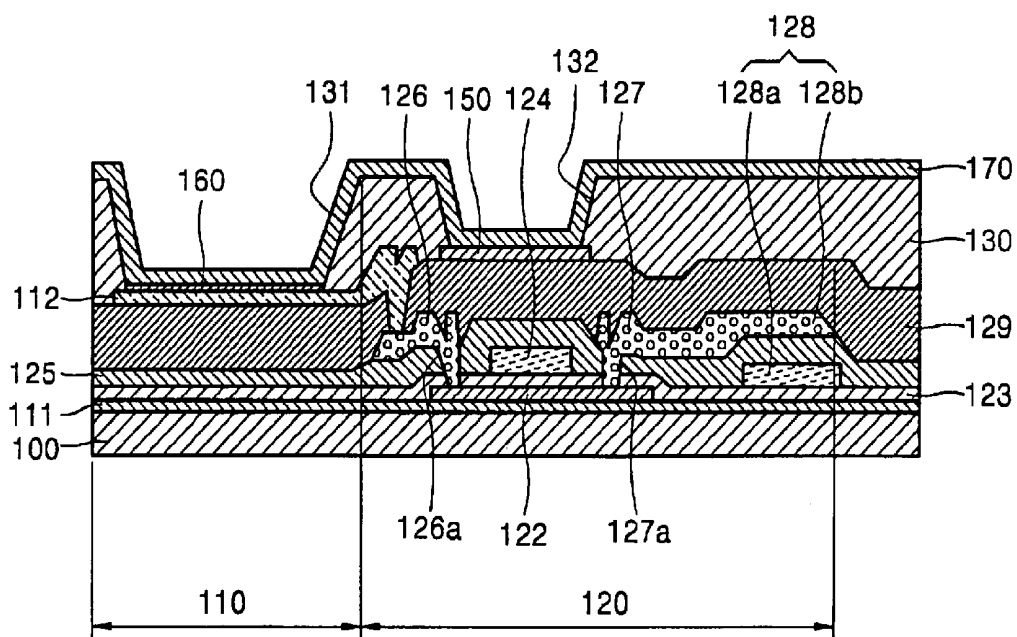

FIG. 2



FIG. 3

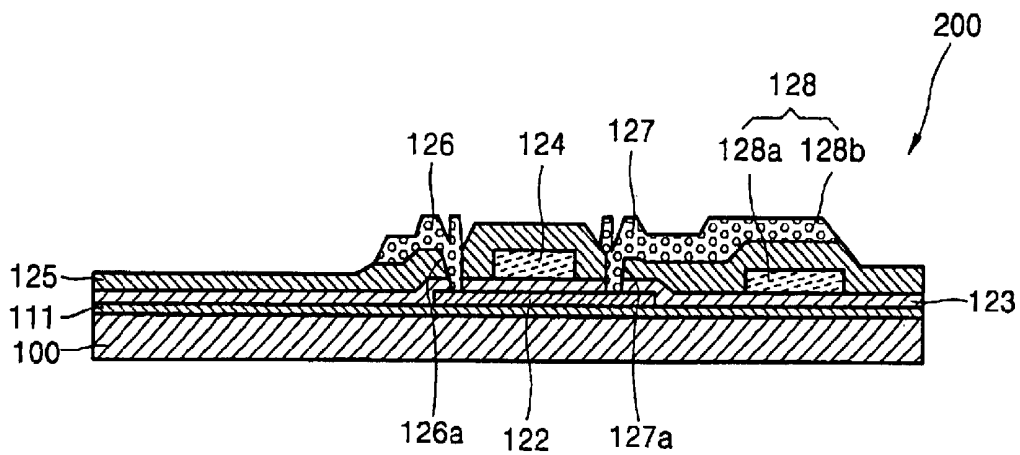

FIG. 4

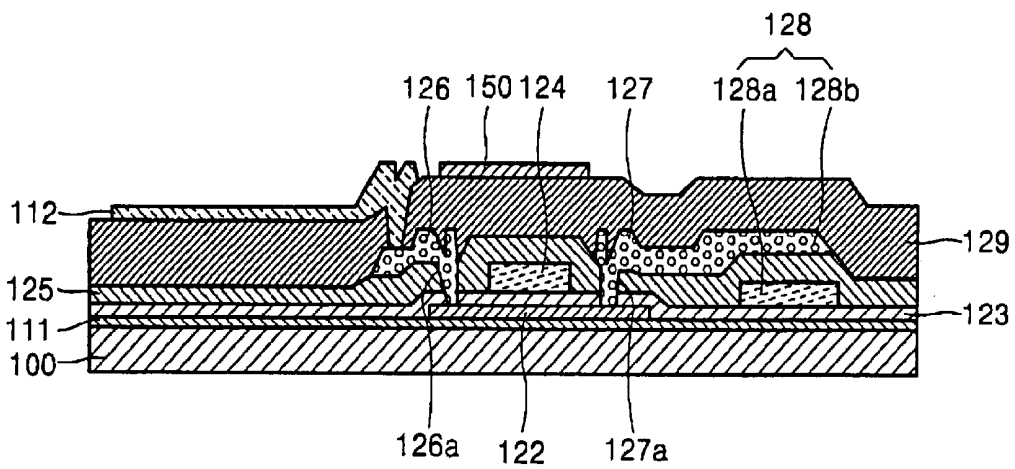

FIG. 5

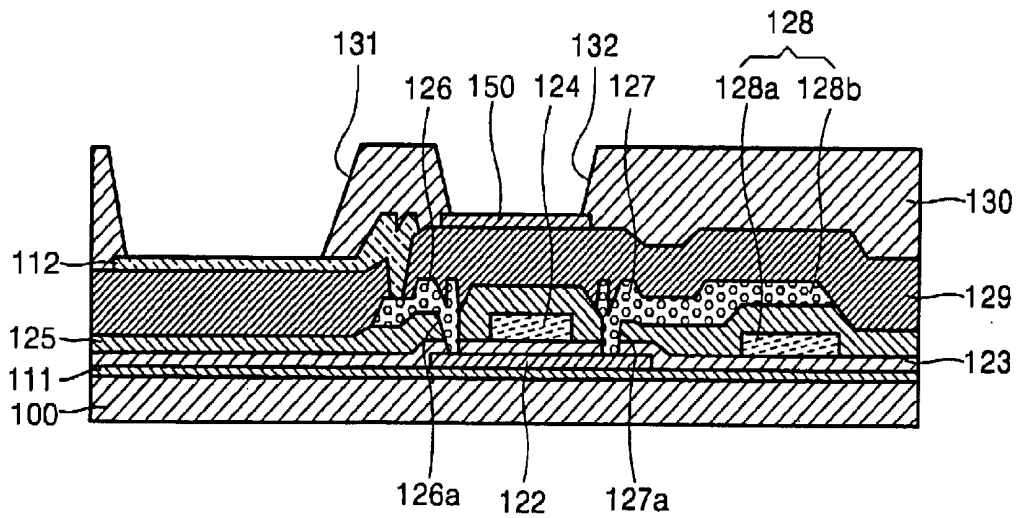

FIG. 6

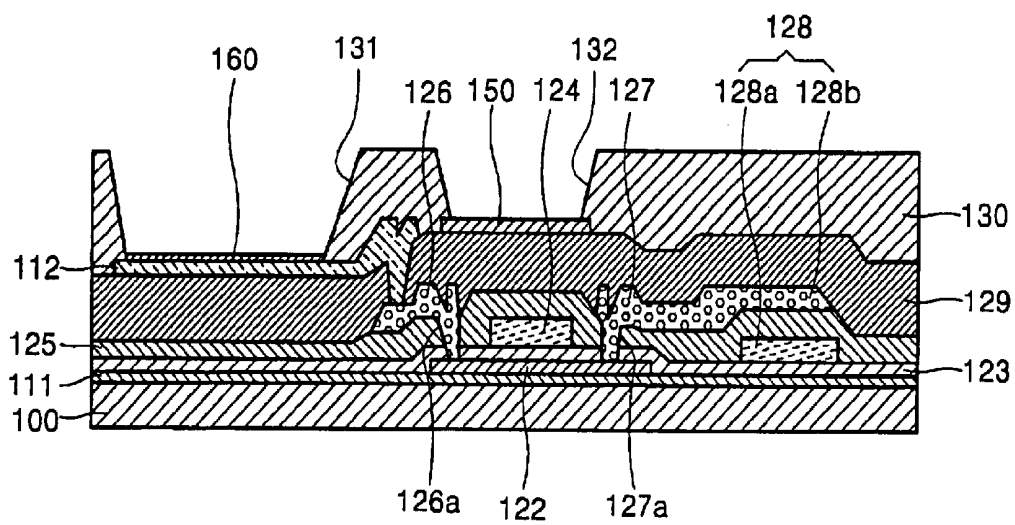
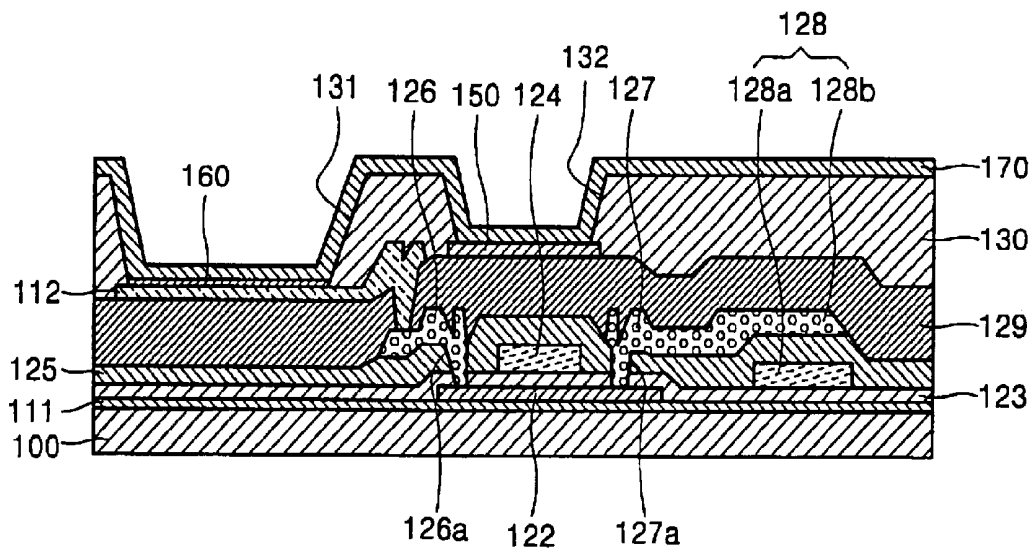

FIG. 7



# ORGANIC ELECTROLUMINESCENT DISPLAY AND METHOD OF MANUFACTURING THE SAME

## CROSS-REFERENCE TO RELATED APPLICATIONS

This application claims the priority of Korean Patent Application No. 2002-57336, filed on Sep. 19, 2002, in the Korean Intellectual Property Office, the disclosure of which is incorporated herein in by reference.

## BACKGROUND OF THE INVENTION

### 1. Field of the Invention

The present invention relates to an organic electroluminescent display, and more particularly, to an organic electroluminescent display with an improved electrode structure.

### 2. Description of the Related Art

Generally, organic electroluminescent displays are self-luminescent displays which emit light by electrically exciting a fluorescent organic compound. They can be operated with low voltage and can be made thin. In addition, organic electroluminescent displays have advantages, such as a wide viewing angle and a fast response speed, that overcome the problems of liquid crystal displays. Accordingly, they have been noted as next generation displays.

In such organic electroluminescent displays, an organic layer is formed in a predetermined pattern on a substrate made of glass or other transparent materials, and electrode layers are disposed under and below the organic layers.

In organic electroluminescent displays having the above-described structure, when positive and negative voltages are applied to the electrodes, holes are moved from an electrode, to which a positive voltage is applied, to a luminescent layer via a hole transport layer. Electrons are moved from an electrode, to which a negative voltage is applied, to the luminescent layer via an electron transport layer. The electrons meet the holes in the luminescent layer, thereby generating excitons. The excitons make transitions from an excitation state to a ground state, thereby provoking fluorescent molecules of the luminescent layer to emit light. As a result, an image is formed.

The light efficiency of organic electroluminescent displays operating as described above is divided into internal efficiency and external efficiency. The internal efficiency depends on the photoelectric conversion efficiency of an organic luminescent material. The external efficiency is referred to as light coupling efficiency and depends on the refractivity of each of layers included in an organic electroluminescent display. Organic electroluminescent displays have lower external efficiency than other displays such as cathode-ray tubes and plasma display panels (PDPs). Accordingly, such organic electroluminescent displays need to be improved in terms of characteristics of displays, such as brightness and a life span.

In the meantime, in organic electroluminescent displays having the above-described structure, as the size of a panel increases, the line resistance of an electrode increases, which causes the brightness of an image to be nonuniform. In particular, when an organic electroluminescent display is driven by a thin-film transistor, the line resistance of a cathode increases, and thus the above problem occurs.

Japanese Patent Publication Nos. sho 62-172691, sho 63-172691, hei 1-220394, and hei 11-283751 disclose conventional organic electroluminescent displays. These con-

ventional organic electroluminescent displays are not provided with an element for reducing the line resistance of a cathode and thus still have a problem of nonuniform brightness of an image due to the line resistance.

## SUMMARY OF THE INVENTION

The present invention provides an organic electroluminescent display for reducing the line resistance of an electrode so that the brightness of an image can be prevented from being nonuniform due to the line resistance.

The present invention also provides an organic electroluminescent display, in which a bus electrode for reducing the line resistance of a cathode is formed in a simple structure, thereby reducing manufacturing cost.

According to an aspect of the present invention, there is provided an organic electroluminescent display comprising a substrate, at least a thin-film transistor, which is formed on the substrate, at least an insulation layer, which cover the thin-film transistor, first electrodes, which are formed in a predetermined pattern on a top surface of the insulation layer and to which a voltage is selectively applied through the thin-film transistor, bus electrodes, which are insulated from the first electrodes, a planarization layer, which is an insulation layer and has openings exposing the first electrodes and the bus electrodes, organic layers, which are formed on a top surface of the first electrodes, and second electrodes, which are formed on a top surface of the organic layer and a top surface of the planarization layer and are electrically connected to the bus electrodes. The second electrodes are made of a transparent material. Thus, the organic electroluminescent display is very effective when the second electrodes are applied to a structure in which light is discharged through a front side. The first electrodes and the bus electrodes are made of the same material. The bus electrodes are formed on a top surface of the insulation layer. Light emitted from the organic layers may be discharged in a direction of the second electrodes.

According to another aspect of the present invention, there is also provided a method of manufacturing an organic electroluminescent display, the method comprising, forming at least a thin-film transistor on a top surface of a substrate, forming at least an insulation layer on a top surface of the thin-film transistor, forming first electrodes, to which a potential is selectively applied through the thin-film transistor, and bus electrodes, which are electrically insulated from the first electrodes on a top surface of the insulation layer, forming a planarization layer on a top surface of the insulation layer to have openings at positions corresponding to the first electrodes and the bus electrodes, forming organic layers on a top surface of the first electrodes, and forming second electrodes on a top surface of the planarization layer and a top surface of selected organic layers and are electrically connected to the bus electrodes.

## BRIEF DESCRIPTION OF THE DRAWINGS

The above and other features and advantages of the present invention will become more apparent by describing in detail preferred embodiments thereof with reference to the attached drawings in which:

FIG. 1 is a cross-section of an organic electroluminescent display according to an embodiment of the present invention; and

FIGS. 2 through 7 are cross-sections of stages in a method of manufacturing an organic electroluminescent display according to an embodiment of the present invention.

## DETAILED DESCRIPTION OF THE INVENTION

Reference will now be made in detail to the embodiments of the present invention, examples of which are illustrated in the accompanying drawings, wherein like reference numerals refer to the like elements throughout. The embodiments are described below in order to explain the present invention by referring to the figures.

FIG. 1 shows an example of an active matrix organic light emitting display (AMOLED), as an organic electroluminescent display according to an embodiment of the present invention. Referring to FIG. 1, a buffer layer 111 is formed on a top surface of a transparent substrate 100. The organic electroluminescent display shown in FIG. 1 is largely divided into a pixel formation section 110, which includes a first electrode 112 for forming a pixel above the buffer layer 111, and a driving section 120, which drive electrodes of the pixel formation section 110 using thin-film transistors (TFTs) and capacitors.

The driving section 120 includes TFTs and capacitors, which are formed on the buffer 111. The TFT includes a P or N type semiconductor layer 122, which is formed in a predetermined pattern on a top surface of the buffer 111; a gate insulation layer, i.e., a first insulation layer 123, which covers the semiconductor layer 122; a gate electrode layer 124, which is formed on a top surface of the first insulation layer 123 so as to correspond to the semiconductor layer 122; a second insulation layer 125, which covers the gate electrode layer 124; and a drain electrode 126 and a source electrode 127, which are formed on the second insulation layer 125 and respectively connected to both ends of the semiconductor layer 122 through contact holes 126a and 127a penetrating the second insulation layer 125 and the first insulation layer 123. The capacitor 128 includes a first auxiliary electrode 128b, which are formed on a top surface of the second insulation layer 125 and connected to the source electrode 127, and a second auxiliary electrode 128a, which is covered with the second insulation layer 125 so as to correspond to the first auxiliary electrode 128b. A third insulation layer 129 is formed on a top surface of the second insulation layer 125 to cover the drain electrode 126 and the source electrode 127.

Here, the shapes of the first, second, and third insulation layers 123, 125, and 129 can vary with a state of the TFT. In addition, the number of the first, second, and third insulation layers 123, 125, and 129 can be reduced, and they are made of a transparent material. And numbers of the TFT and the capacitor may be varied.

In the meantime, the pixel formation section 110 includes the first electrode 112, which is formed on a top surface of the third insulation layer 129 stacked on the transparent substrate 100 and is electrically connected to the drain electrode 126. A bus electrode 150 is formed in a predetermined pattern on a top surface of the third insulation layer 129 to be electrically insulated from the first electrode 112.

A planarization layer 130, i.e., a fourth insulation layer, is formed on an entire surface of the third insulation layer 129 on which the first electrode 112 and the bus electrode 150 are formed. The planarization layer 130 has a first opening 131, which exposes a part of the first electrode 112, and a second opening 132, which exposes a part of the bus electrode 150. An organic layer 160 is formed on a top surface of the first electrode 112 exposed through the first opening 131. A second electrode 170 is formed on the organic layer 160 and the planarization layer 130 to be electrically connected to the bus electrode 150. Here, the first electrode 112 and the bus

electrode 150 are made of the same material. It is preferable that the bus electrode 150 is formed in a predetermined pattern so as to reduce the line resistance of the second electrode 170.

In an organic electroluminescent display having the above-described structure according to the present invention, when a predetermined voltage is applied to the first electrode 112 through the driving section 120, a voltage is applied to the second electrode 170. Then, holes move from the first electrode 112 to a luminescent layer of the organic layer 160, and electrons move from the second electrode 170 to the luminescent layer. The electrons meet the holes in the luminescent layer, thereby generating excitons. The excitons make transitions from an excitation state to a ground state, thereby provoking fluorescent molecules of the luminescent layer to emit light. The emitted light is discharged through a front side (when the second electrode 170 is made of a transparent material) or a rear side.

In the above-described procedure, since the second electrode 170 is electrically connected to the bus electrode 150 having a predetermined pattern, current and voltage flowing through the second electrode 170 can be prevented from dropping. Due to this prevention of the drop of voltage and current, current and voltage for exciting the organic layer 160 positioned between the first and second electrodes 112 and 170 can be maintained constant. As a result, the brightness of an image can be fundamentally prevented from being nonuniform throughout the image.

FIGS. 2 through 7 are cross-sections of stages in a method of manufacturing an organic electroluminescent display having the above-described structure, according to an embodiment of the present invention.

Referring to FIGS. 2 and 3, the buffer layer 111 is formed on a top surface of the transparent substrate 100, and then at least a TFT layer 200 is formed on a top surface of the buffer layer 111. The TFT layer 200 can be formed by a typical method, and thus detailed description thereof will be omitted.

Referring to FIG. 4, after completion of the TFT layer 200, the third insulation layer 129 is formed on a top surface of the TFT layer 200. The first electrode 112, to which a potential is selectively applied through the TFT layer 200, and the bus electrode 150, which is electrically insulated from the first electrode 112, are formed on a top surface of the third insulation layer 129. Here, the first electrode 112 and the bus electrode 150 are formed by bringing an evaporation mask (not shown), which has a pattern for the first electrode 112 and a pattern for the bus electrode 150, into close contact with the third insulation layer 129 and evaporating a material for the first electrode 112 and a material for the bus electrode 150. Since the first electrode 112 and the bus electrode 150 can be made of the same material, they can be simultaneously formed through evaporation. The formation of the first electrode 112 and the bus electrode 150 is not restricted to the above-described embodiment, but any method enabling the first electrode 112 and the bus electrode 150 to be formed simultaneously can be used.

As shown in FIGS. 5 and 6, the planarization layer 130, i.e., the fourth insulation layer, having the first and second openings 131 and 132 at positions respectively corresponding to the first electrode 112 and the bus electrode 150, are formed on the third insulation layer 129. The organic layer 160 is formed on a top surface of the first electrode 112.

As shown in FIG. 7, the second electrode 170 is formed in a predetermined pattern on a top surface of the planariza-

tion layer **130** and a top surface of the organic layer **160** to be electrically connected to the bus electrode **150**. The second electrode **170** is formed by bringing a mask having the pattern of the second electrode into close contact with the planarization layer **130** having the first and second openings **131** and **132** and performing evaporation.

As described above, line resistance, which increases with an increase in the size of an organic electroluminescent display, is reduced, where a bus electrode electrically connected to a second electrode is formed on a top surface of an insulation layer having a first electrode, thereby accomplishing uniform brightness of an image.

Although a few embodiments of the present invention have been shown and described, it will be appreciated by those skilled in the art that changes may be made in these elements without departing from the principles and spirit of the invention, the scope of which is defined in the appended claims and their equivalents.

What is claimed is:

1. An organic electroluminescent display comprising:
  - a substrate;
  - at least a thin-film transistor, which is formed on the substrate;
  - at least an insulation layer, which cover the thin-film transistor;
  - first electrodes, which are formed in a predetermined pattern on a top surface of the insulation layer and to which a voltage is selectively applied through the thin-film transistor;
  - bus electrodes, which are insulated from the first electrodes;
  - a planarization layer, which is an insulation layer and has openings exposing the first electrodes and the bus electrodes;
  - organic layers, which are formed on a top surface of the first electrodes; and
  - second electrodes, which are formed on a top surface of the organic layer and a top surface of the planarization layer and are electrically connected to the bus electrodes.

2. The organic electroluminescent display of claim **1**, wherein the second electrodes are made of a transparent material.

3. The organic electroluminescent display of claim **1**, wherein the first electrodes and the bus electrodes are made of the same material.

4. The organic electroluminescent display of claim **3**, wherein the first electrodes and the bus electrodes are made of metal.

5. The organic electroluminescent display of claim **1**, wherein the bus electrodes are formed on a top surface of the insulation layer.

6. The organic electroluminescent display of claim **1**, wherein light emitted from the organic layers is discharged in a direction of the second electrodes.

7. A method of manufacturing an organic electroluminescent display, the method comprising:

- forming at least a thin-film transistor on a top surface of a substrate;
- forming at least an insulation layer on a top surface of the thin-film transistor;
- forming first electrodes, to which a potential is selectively applied through the thin-film transistor, and bus electrodes, which are electrically insulated from the first electrodes on a top surface of the insulation layer;
- forming a planarization layer on a top surface of the insulation layer to have openings at positions corresponding to the first electrodes and the bus electrodes;
- forming organic layers on a top surface of the first electrodes; and
- forming second electrodes on a top surface of the planarization layer and a top surface of selected organic layers and are electrically connected to the bus electrodes.

\* \* \* \* \*

专利名称(译)	有机电致发光显示器及其制造方法		
公开(公告)号	<a href="#">US6917160</a>	公开(公告)日	2005-07-12
申请号	US10/663800	申请日	2003-09-17
申请(专利权)人(译)	三星SDI CO. , LTD.		
当前申请(专利权)人(译)	三星DISPLAY CO. , LTD.		
[标]发明人	KOO JAE BON PARK SANG IL		
发明人	KOO, JAE-BON PARK, SANG-IL		
IPC分类号	H05B33/26 H01L27/32 H01L51/50 H05B33/10 H05B33/22 H01J1/62		
CPC分类号	H01L27/3244 H01L51/5221 H01L51/5228 H05B33/26 H01L27/3246 H01L51/56		
审查员(译)	帕特尔贵宾		
优先权	1020020057336 2002-09-19 KR		
其他公开文献	US20040056591A1		
外部链接	<a href="#">Espacenet</a> <a href="#">USPTO</a>		

摘要(译)

提供一种有机电致发光显示器及其制造方法。有机电致发光显示器包括基板，至少一个薄膜晶体管，其形成在基板上，至少一个绝缘层，其覆盖薄膜晶体管，第一电极，其在顶部以预定图案形成绝缘层的表面并且通过薄膜晶体管选择性地施加电压，总线电极与第一电极绝缘，平坦化层是绝缘层并具有暴露第一电极和总线的开口电极，形成在第一电极的顶表面上的有机层，以及形成在有机层的顶表面和平坦化层的顶表面上并且电连接到汇流电极的第二电极。

